



# 4

## Disc Harrow

---

In this section you will find discs for disc harrow and disc tilling in a wide variety of concave forms and sizes. **BELLOTA** conducts very strict quality checks, guaranteeing that its discs for disc harrow will all be totally uniform, which means that any work you do with them will be excellent. The right hardness ensures the ideal level of flexibility and toughness to absorb impacts without breakage, and yet at the same time to resist the most abrasive soil conditions. All this guarantees that the discs pass the toughness test known as "the ball test," which assesses their resistance to fracture.

**BELLOTA** discs for disc harrow were the first discs manufactured out of boron steel, guaranteeing them a perfect balance between hardness and toughness, which means maximum breakage-free service life.

---

## Cover crop

---

Dans cette section, nous trouvons les disques **BELLOTA** pour herse et charrues à disques, avec toutes les concavités et dimensions. **BELLOTA** dispose de contrôles de qualité très strictes qui procurent une parfaite homogénéité du disque, garantissant un excellent travail. Une dureté correcte assure flexibilité et ténacité adéquates pour absorber les impacts, sans cassures, tout en résistant aux conditions de terrain abrasif. Tout ceci permet de garantir que chaque disque **BELLOTA** surpasse le "test de la bille", qui permet de vérifier la résistance à la cassure.

Les disques **BELLOTA** ont été les premiers à être fabriqués avec un acier au bore en garantissant un équilibre parfait entre dureté et ténacité, et donc une longévité maximale sans cassures.

---

# CONCAVITIES RANGE GAMME DE CONCAVITÉS

## Benefits:

The widest series on the market, that adapts to all types of machines, axles, soil types and working conditions to be performed.  
Specialised in developing customised models.

## Characteristics:

- Boron steel.
- Hardness: 50 +/-2 HRc guaranteed via the use of an automatic control system in heat treatment. This hardness ensures flexibility and the ability to absorb impacts without breaking, providing the disc a longer life-span, even in the most severe soil conditions.
- Lathed, precise and uniform edges, obtaining optimal soil penetration.
- Surpasses the ball test (tenacity test).

The right disc hardness is key to ensuring the maximum resistance to disc wear, while also providing the ability to bend and recuperate the shape memory without breaking. This is achieved with a precise and controlled heat treatment. Bellota ensures the right hardness in 100% of its discs, due to our automatic control system:

if the disc has not received the right treatment, the process automatically rejects it.

## Use:

Discs for harrow and ploughs.

## Avantages:

La plus vaste gamme du marché s'adaptant à tout type de machines, axes, conditions de sol et type de travail à effectuer.  
Spécialisés dans le développement de modèles à la demande.

## Caractéristiques:

- Acier au bore.
- Dureté : 50 +/-2 HRc garantie grâce à un système de contrôle automatique lors du traitement thermique. Cette dureté assure la flexibilité et la capacité à absorber les impacts sans ruptures. La vie utile du disque est donc supérieure, même avec des conditions de travail sévères.
- Biseaux usinés, précis et uniformes, garantissant une pénétration optimum dans le sol.
- Conformés au test de la bille (test de ténacité).

La dureté adéquate du disque est primordiale afin d'assurer la résistance maximale à l'usure et en même temps; garder la flexibilité nécessaire pour se déformer en cas de choc et retrouver sa forme originale sans souffrir de cassure. C'est le traitement thermique précis et contrôlé qui assure la dureté requise des 100% des disques, grâce à un système de contrôle automatique dans installations, étant donné que si le disque n'a pas reçu le bon traitement, le processus le rejette automatiquement.

## Utilisations:

Disques pour pulvérisateur, cover-crop ou pour charrue à disque.

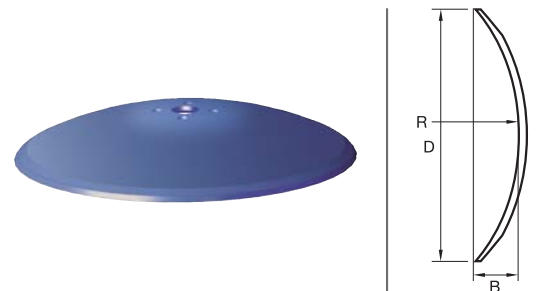

## Blades / Disques bombés

### Concavity features / Tableau des concavités

Bevel Biseau	1942		1903		1904		1905		1906		1907		1948		1910	
	1932		1913		1914		1915		1916		1917		1938		1920	
"	R: 498 ± 8 mm		R: 545 ± 8 mm		R: 595 ± 10 mm		R: 620 ± 10 mm		R: 680 ± 10 mm		R: 722 ± 10 mm		R: 797 ± 15 mm		R: 983 ± 15 mm	
	B mm	D mm	B mm	D mm	B mm	D mm	B mm	D mm	B mm	D mm	B mm	D mm	B mm	D mm	B mm	D mm
10					15	254			11	254						
11									14	281						
12									15	303						
13									20	331						
14			29	353	26	355	26	356	23	357						
15									26	377						
16	43	410	39	413	36	415	34	416	32	419	30	417	27	418	22	420
18	54	456	49	457	45	460	43	460	40	463	37	462	34	464	28	465
20	67	506	61	508	58	511	53	512	50	515	46	512	43	516	35	519
22	84	556	76	560	70	562	67	565	61	567	57	567	52	570	43	574
24	100	605	90	607	83	609	80	612	73	616	67	614	62	619	50	624
26	120	655	110	656	100	661	96	664	87	670	81	668	73	676	60	680
28	141	695	127	704	117	708	112	711	102	722	94	718	85	726	70	733
30					133	754	128	752	114	762			97	770		
32									132	814			101,5	816		
34													128	865		
36									174	915			146	922		

See page 108 to see the different bevels. / Consulter page 108 les différents biseaux.

### Conical blades / Disques coniques

Concavity features / Tableau des concavités

Bevel Biseau	A	1971			
	B	1976		1977	
"	R: 645 ± 10 mm				
		B mm	D mm	B mm	D mm
18		64	450		
20		76	500	60	502
22		92	550	73	557
24		106	595	81	602
26		125	650	96	657
28		143	690	108	707
30				123	765
32				134	820
36				166	910

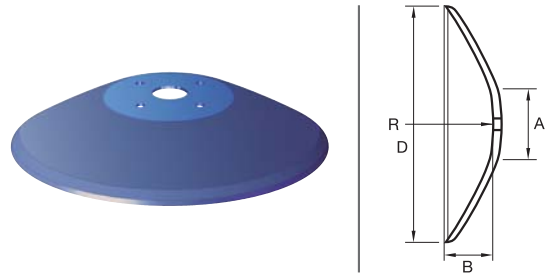

### Flat centre blades / Disques à fond plat

Concavity features / Tableau des concavités

Bevel Biseau	A	1964		1965		1953		1954		1966		1956		1967 1968*	
		A: 110 ± 5 mm		A: 130 ± 5 mm		A: 155 mm		A: 155 mm		A: 160 ± 5 mm		A: 170 ± 5 mm		A: 180 ± 5 mm	
"		B mm	D mm	B mm	D mm	B mm	D mm	B mm	D mm	B mm	D mm	B mm	D mm	B mm	D mm
	14								24	355					
15								28	378						
16	37	414	36	415	15	421	35	415			10	406	16	422	
18	47	459	45	460	21	466	44	458	36	463	11,5	457	22	457	
20	58	510	56	511	29	518	57	510	45	514	14	508	28	520	
22			70	563	39	572			57	566	17	582			
24			84	609	49	620			69	615					
26					62	674			79	672					
28					76	724			95	720					
30									106	762					
32									123	817					

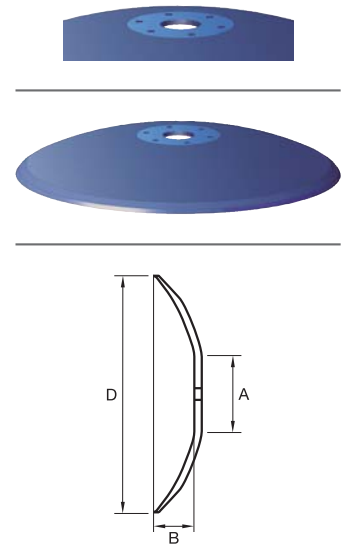

\* Outside bevel 30° / Biseau extérieur 30°

### Flat back centre blades / Disques à fond embouti

Concavity features / Tableau des concavités

Bevel Biseau	A	1960		1959		1961		1952	
	B	1969		1963		1962			
"		A: 130 ± 5 mm		A: 130 ± 5 mm		A: 170 ± 5 mm		A: 210 ± 5 mm	
		B mm	D mm	B mm	D mm	B mm	D mm	B mm	D mm
16				32	413				
18	49	460	41	462	46	461			
20	60	513	49	509	54	512			
22	71	565			65	565	48	572	
24	84	614			80	615	65	618	
26	96	668			91	670	77	675	
28					105	720	92	724	
30							108	770	
32							126	817	

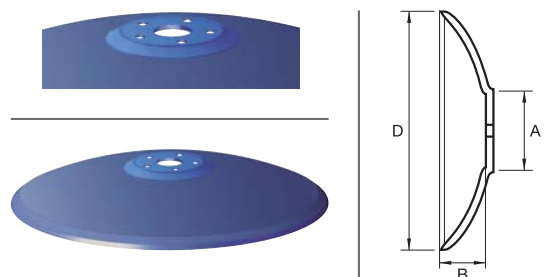

### Characteristics:

- All inPHInium discs have a hardness of 55-2 HRc and surpass the ball test. The perfect balance of long lasting without breaking.
- inPHInium disc: the disc with the longest lifespan without breaking on the market.
- The harder the disc, the less toughness it has. A disc is considered tough when it surpasses the ball test. BELLOTA has been able to obtain a perfect balance of hardness and toughness in its inPHInium disc with its new steel and special Borodur® treatment.
- A product range adapted to each client's requirements.

### Caractéristiques:

- Tous les disques inPHInium ont une dureté de 55-2 HRc et ont passé avec succès le test de la boule. L'équilibre parfait pour une durée de vie maximum sans cassures.
- Le disque inPHInium, le disque ayant la plus longue durée de vie du marché sans cassures.
- Plus le disque est dur, moins il est solide. Un disque est considéré comme étant solide lorsqu'il a passé avec succès le test de la boule. Grâce au nouvel acier et au traitement spécial Borodur®, BELLOTA a conçu le disque inPHInium qui offre un équilibre parfait entre la dureté et la solidité.
- Gamme répondant aux besoins de chaque client.

### inPHInium

∅ "	→ ←		F
22"	6	50	14
24"	6	50	14
26"	6	50	12
28"	6	50	12



### inPHInium



# SPECIALTY CONCAVE DISCS

## DISQUES BOMBÉS CONCAVES SPÉCIAUX

### 1992 VORTEX

Ref. Réf.	ø "	ø mm		Grs.		N° waves Ondulations	O	Flat Centre Fond Plat	F
1992	17"	441	6	6.350	50	18	28	230	16
1992	18"	458	6	7.060	50	18	32	230	16
1992	20"	511	6	9.700	50	18	32	230	16
1992	22"	565	6	10.450	50	18	32	230	14
1992	24"	618	6	13.540	50	18	32	230	14

Vortex® is a trademark of CFC Distributors. / Vortex® est une marque, propriété de CFC Distributors.  
Vertical tillage disc / Disque pour Vertical Tillage

1992 VORTEX





1992 VORTEX

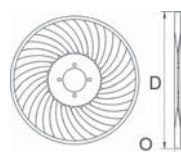

1992 VORTEX



### 1927 VORTEX

Ref. Réf.	ø "	ø mm		Grs.		N° waves Ondulations	O	B	F
1927	20"	520	6	8.160	50	20	12,5	23,5	16
1927	22"	574	6	12.530	50	20	14	28,5	14

Vortex® is a trademark of CFC Distributors. / Vortex® est une marque, propriété de CFC Distributors.  
Vertical tillage disc / Disque pour Vertical Tillage

1927-D VORTEX





1927-I VORTEX

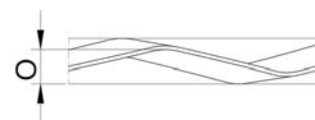

1927-D VORTEX



### 1957 VORTEX

Ref. Réf.	ø "	ø mm		Grs.		N° waves Ondulations	O	Flat Centre Fond Plat	B	F
1957	18"	467	6	7.060	50	20	9	120	23,5	16
1957	20"	520	6	8.160	50	20	12,5	120	25,3	16
1957	22"	574	6	12.530	50	20	14	120	31	14

Vortex® is a trademark of CFC Distributors. / Vortex® est une marque, propriété de CFC Distributors.  
Vertical tillage disc / Disque pour Vertical Tillage  
With flat centre / Avec fond plat

1957-D VORTEX



1957-I VORTEX



1957-D VORTEX

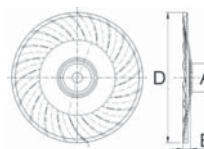

4.3

# SPECIALTY CONCAVE DISCS DISQUES BOMBÉS CONCAVES SPÉCIAUX

## 1958 VT-REX

Ref. Réf.	ø "	ø mm	→ ←	A	B	R mm	N° waves Ondulations	O	Grs.		F
1958	18"	462	5	130	35,5	610	20	8,5	5.100	50	16
1958	20"	514	5	130	45	610	20	8,5	7.500	50	16
1958	20"	514	6	130	45	610	20	8,5	8.000	50	16
1958	22"	568	5	130	48	610	20	8,5	8.900	50	16
1958	22"	568	6	130	48	610	20	8,5	10.000	50	16

VT Rex



VT Rex

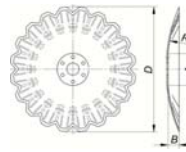

## 1926 TERRAMAX

Ref. Réf.	ø "	ø mm	→ ←	Grs.		N° waves Ondulations	O	B	F
1926	18"	463	6	7.050	50	32	7	40	16
1926	20"	515	4	6.180	50	32	8	50	16
1926	22"	567	4	7.650	50	32	8	61	16
1926	24"	616	5	11.380	50	32	9	73	14
1926	24"	616	6	13.540	50	32	10	73	14
1926	26"	670	6	16.630	50	32	10	87	12
1926	28"	720	8	26.010	50	32	12	101	12

Recommended for soft soils. / Recommandé pour les terres molles.  
The disc has a better lifetime than the conventional notched disc. / Le disque a une plus longue durée de vie que le disque cranté traditionnel.

1926 TERRAMAX



1926 TERRAMAX



1926 TERRAMAX



1926 TERRAMAX





## 1905 CE KIRAI

Ref. Réf.	ø "	ø mm	→ ←	Grs.		N. of petals N. de pétales	B	R	R mm	F
1905 CE	24"	620	6	12.350	50	5	80	620	620	14
1905 CE	26"	657	6	15.000	50	5	96	620	620	12
1905 CE	28"	711	8	17.780	50	6	112	620	620	12

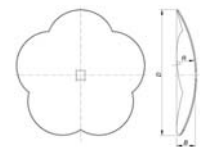
1905 CE



## 1906 LUR

Ref. Réf.	ø "	ø mm		B	R mm	N. of petals N. de pétales	Grs.		F
1906 D	32"	810	10	132	680	5	31.800	50	6
1906 I	32"	810	10	132	680	5	31.800	50	6

LUR RIGHT HAND



LUR LEFT HAND



LUR



## DISKATOR

ø "		Grs		F
22"	4,5	7.810	100	14

Diskator



I Left / Gauche

D Right / Droite

F Articles manufactured upon order / Fabrication de l'article sur commande



## 4.4 CONCAVE DISC BEVELS BISEAUX DISQUES BOMBÉS

Both the notches and bevels play an important role in current working conditions. **BELLOTA** designs the edges so as to be able to cut the stubble and penetrate well into the ground. An extremely sharpened edge can be cracked and broken, but an overly dull one will not penetrate into the ground or suitably cut the stubble.

Aussi bien les créneaux que les biseaux jouent un rôle important dans les conditions de travail actuels. **BELLOTA** conçoit les biseaux à leur juste mesure, de sorte qu'ils puissent couper la chaume et pénétrer également dans la terre. Un biseau trop affûté peut s'effriter et se casser, et à l'inverse, un tranchant trop épais ne pénètre pas dans la terre et ne coupe pas la chaume convenablement.

### Outside-inside bevel / Biseau extérieur-intérieur

→ ← mm	L mm	H mm
2	5	0,7
2,5	6	0,8
3	6,5	1,1
3,5	8	1,2
4	9	1,4
4,5	10,5	1,5
5	11	1,8

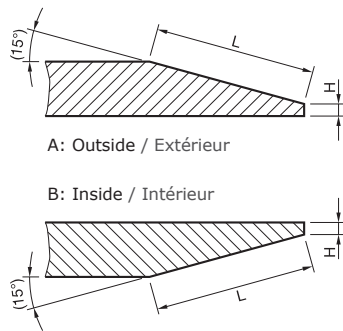

→ ← mm	L mm	C mm	D mm
6	14	1,3	3,3
6,5	15	1,5	3,6
7	16	1,6	3,9
8	18	1,8	4,4
10	24	2,2	5,5
12	29	2,7	6,5

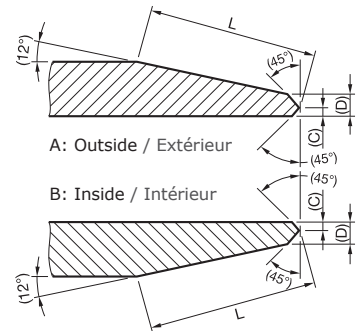

A: Ref. 1903, 1904, 1905, 1906, 1942, 1948, 1952, 1959, 1960, 1961, 1964, 1965, 1966, 1967, 1971  
B: Ref. 1913, 1914, 1915, 1916, 1932, 1938, 1962, 1963, 1969, 1976, 1977

### Outside-inside edge off bevel Biseau ébarbé extérieur-intérieur

→ ← mm	L mm	C mm	D mm
2	5	0,5	1,1
2,5	6	0,6	1,4
3	7	0,7	1,7
3,5	8	0,8	2
4	10	0,9	2,2
4,5	11	1	2,5
5	12	1,1	2,8

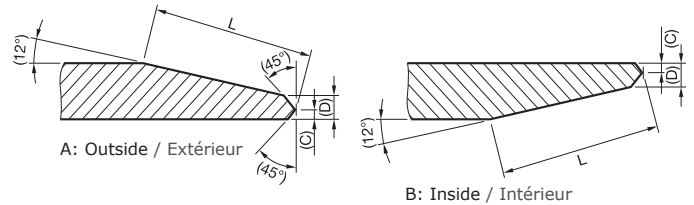

### Outside-inside bevel RM Biseau RM extérieur-intérieur

→ ← mm	L mm	I mm	Angle	C mm	D mm
4	20	4,5	0°	1	2,8
4,5	23	5		1,1	3,2
5	24	5,5		1,2	3,5
6	25	6,5		1,3	4,3
6,5	26	7,5		1,4	4,7
7	26,5	8	45°	1,5	5
8	28	8,5		2,25	5,7
10	32	10		2,5	7
12	36	11		4,25	8,5

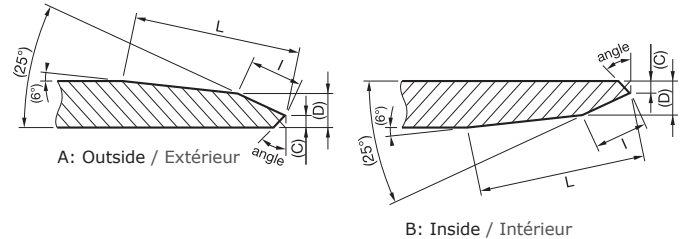

### Outside bevel 30° / Biseau 30° extérieur

→ ← mm	L mm	H mm
3	3,5	0,8
3,5	4,5	
4	5	
4,5	6	
5	7	
6	8,5	

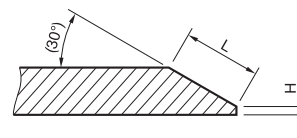

Ref. 1956, 1968

# CONCAVE DISC NOTCHES CRÉNEAUX DISQUES BOMBÉS

## Standard / Standard

Ø "	Number of notches Nombre de créneaux	A mm Average values Valeurs moyennes	B mm
16	8	88	35
18	9	88	35
20	10	88	35
22	11	86	35
24	12	86	35
26	13	90	40
28	14	90	40
30	14	89	40
32	15	88	40
36	16	87	40

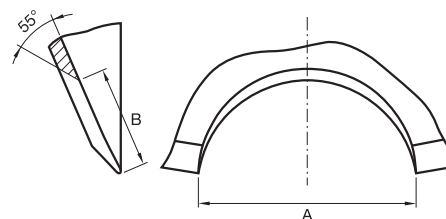

Interior and exterior edges  
Tranchant intérieur et extérieur

## Special small notches / Petit créneau spécial

Ø "	Number of notches Nombre de créneaux	A mm	B mm
22	11	75	50
24	12	75	50
26	13	80	60
28	14	80	60

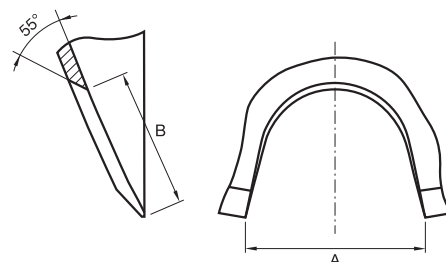

Only for exterior edge  
Seulement pour le tranchant extérieur

## Special large notches / Grand créneau spécial

Ø "	Number of notches Nombre de créneaux	A mm	B mm
24	12	85	50
26	13	85	50
28	14	95	60
30	14	95	60
32	15	95	60

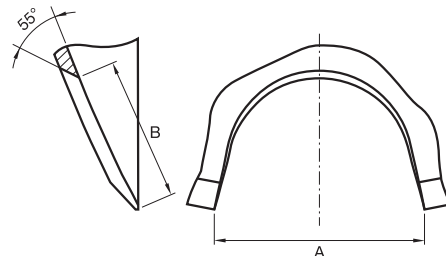

Only for exterior edge  
Seulement pour le tranchant extérieur

## Mini-notches / Créneau mini

Ø "	Number of notches Nombre de créneaux	A mm	B mm
16	20	22	11
18	20	22	11
20	20	22	11

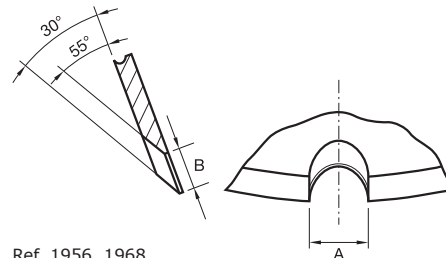

Ref. 1956, 1968

Ask us about the possibility of manufacturing these notches according to the required model.  
Consulter la possibilité de fabrication de ces créneaux selon le modèle demandé.

## Center holes / Non ébarbé

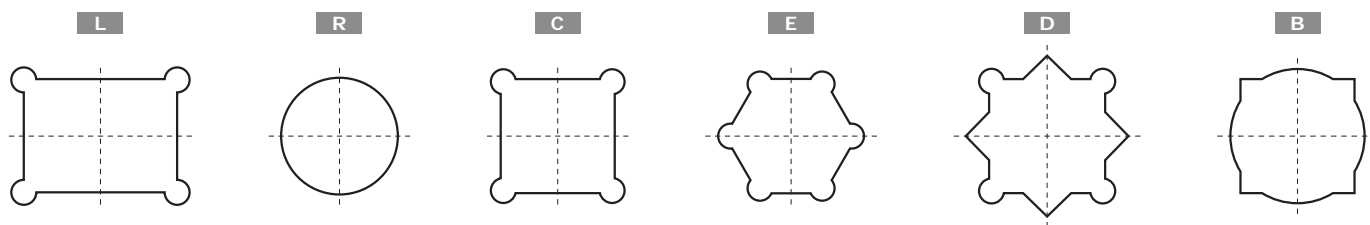



### PLAIN / LISSES

ø "	±	Grs		F
10"	2,5	860	100	38
11"	2	870	100	36
11"	3	980	100	36
12"	2	1.040	100	26
12"	2,5	1.280	100	36
12"	3	1.590	100	36
12"	4	1.900	100	36
12"	5	2.400	100	36
13"	2,5	1.550	100	26
14"	3	2.030	100	36
14"	3,5	2.360	100	33
14"	4	2.710	100	36
14"	4,5	3.050	100	35
14"	5	3.360	100	44
15"	4	3.480	100	33
16"	3	2.860	100	16
16"	3,5	3.320	100	16
16"	4	3.820	100	16
16"	4,5	4.300	100	16
16"	5	4.740	100	16
18"	3,5	4.140	100	16
18"	4	4.770	100	16
18"	4,5	5.390	100	16
18"	5	5.930	100	16
18"	6	7.050	100	16
20"	3,5	5.390	100	16
20"	4	6.180	100	16
20"	4,5	6.960	100	16
20"	5	7.650	100	16
20"	6	9.080	100	16
22"	4	7.650	100	14
22"	4,5	8.620	100	14
22"	5	9.490	100	14
22"	6	11.280	50	14
24"	4,5	10.320	50	14
24"	5	11.380	50	14
24"	6	13.540	50	14
24"	7	15.800	50	14
24"	8	18.000	50	14
26"	5	13.830	50	12
26"	6	16.630	50	12
26"	7	19.390	50	12
26"	8	22.130	50	12
28"	6	19.530	50	12
28"	7	22.790	50	12
28"	8	26.010	50	12
30"	6	22.150	25	7
30"	8	29.530	25	7
30"	10	36.330	25	7
32"	8	34.220	25	6
32"	10	42.150	25	6
34"	12	63.400	25	6
36"	12	67.610	25	6



## NOTCHED / CRÉNELÉS

ø "		Grs		F
16"	3	2.490	100	16
16"	3,5	2.880	100	16
16"	4	3.320	100	16
16"	4,5	3.720	100	16
16"	5	4.110	100	16
18"	3,5	3.650	100	16
18"	4	4.200	100	16
18"	4,5	4.740	100	16
18"	5	5.210	100	16
18"	6	6.180	100	16
20"	3,5	4.860	100	16
20"	4	5.570	100	16
20"	4,5	6.270	100	16
20"	5	6.890	100	16
20"	6	8.160	100	16
22"	4	6.930	100	14
22"	4,5	7.810	100	14
22"	5	8.590	100	14
22"	6	10.190	50	14
24"	4,5	9.440	50	14
24"	5	10.390	50	14
24"	6	12.350	50	14
24"	7	14.480	50	14
24"	8	16.640	50	14
26"	5	12.490	50	12
26"	6	15.000	50	12
26"	7	17.490	50	12
26"	8	19.940	50	12
28"	6	17.780	50	12
28"	7	20.730	50	12
28"	8	23.650	50	12
30"	6	20.400	25	7
30"	8	27.160	25	7
30"	10	33.400	25	7
32"	8	31.680	25	6
32"	10	39.000	25	6
34"	12	59.600	25	6
36"	12	63.550	25	6







Any kind of disc may be manufactured as plain or notched / Tout type de disque peut être fabriqué lisse ou crénelé

## CONCAVE DISC GUARANTEE GARANTIE DISQUES BOMBÉS

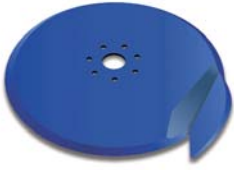
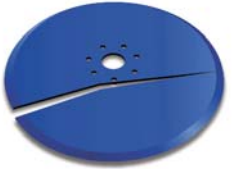
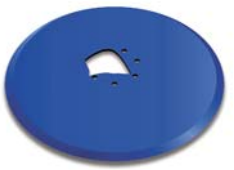
All **BELLOTA** discs are produced under the strict quality specifications that ensure the hardness and uniformity throughout the disc. However, certain ground conditions may provoke some breaking. With the aim of clarifying why these situations occur, we have created the following table:

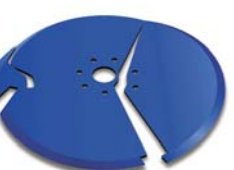
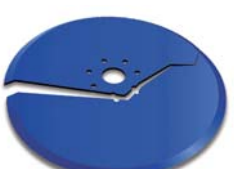
Tous les disques **BELLOTA** sont fabriqués sous des spécifications de qualité très strictes qui assurent la dureté et l'uniformité de tout le disque. Cependant, sous certaines conditions de terrain, des problèmes de rupture peuvent survenir. Dans le but d'éclaircir les raisons de ces situations, nous avons rédigé le tableau suivant:

	Type of failure Type de rupture	Cause Cause	Guarantee Garantie
	Crack Fissure	Defective material Matériau défectueux	Full credit granted Garantie complète
	Straight break Cassure droite		
	Breakout of center of disc Cassure au centre du disque	Tilled over rocks or stumps, loose bolts and excessive disc flexing Labourage sur pierres, pression excessive sur le disque et boulons desserrés	Credit is not offered La garantie ne couvre pas
	Irregular break Cassure irrégulière	Contact with rocks, stumps or other solid objects Contact avec des cailloux ou autres objets solides	
			
			
	Chipped and dented edges Éclat et biseaux dentés		

## 4.8 DISC SUPPORT SUPPORT DE DISQUE

### Benefits:

High-elasticity and strength tines for rapid or light harrowing.

### Characteristics:

- Tailor-made tine design according to leading edge angle and bushing for each client.
- Able to supply all necessary elements.

### Use:

For speed harrow with discs up to 22". Bellota recommends to mount with 18" or 20" discs.

### Avantages:

Dent à grande élasticité et résistance pour herse rapides ou légères.

### Caractéristiques:

- Dent conçue sur mesure selon l'angle d'attaque et le moyeu de chaque client.
- Possibilité de fournir tous les éléments nécessaires.

### Utilisations:

Pour herse rapides ou légères avec disques de 22". Bellota recommande le montage avec disques de 18" ou 20".

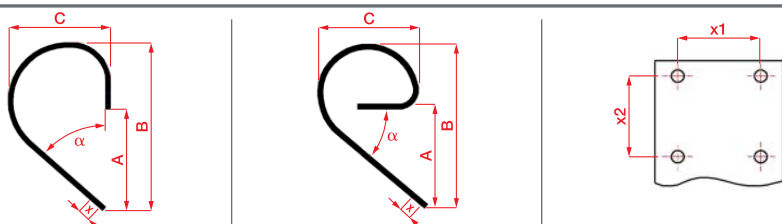

### 2512 BRG A

Ref. Réf.	Chasis Châssis	Grs.		A	B	C	x1	x2	$\alpha$	M	
2512 BRG A	60X60 / 70x70	9.000	90X14	273	429	264	60	30	40°	M12 (4)	100

Assembly with clamp / Montage avec bride

Clamp for 60x60 chasis: 125126060 (M14). Clamp for 70x70 chasis: 125127070 (M14). / Bride pour châssis 60x60: 125126060 (M14). Bride pour châssis 70x70: 125127070 (M14).

2512 BRG A



### Clamps for 2512 BRG A / Brides pour 2512 BRG A

Ref. Réf.	Grs.	Chasis Châssis	M	F
12512KIT 7070	3.000	70x70	M12(2) /M14(1)	
12512-6060	1.100	60x60		100
12512-7070	1.200	70x70		100

12512KIT7070: Robust and heat treated clamp. It stops the tine moving sideways in the frame. / 12512KIT7070: Bride robuste et traitée thermiquement. Évite les mouvements latéraux de la dent sur la châssis.

### 12512KIT7070

Contains / Contient	Units / Unités	Bolt / Boulon	Units / Unités	Nut / Écrou
	2	M12x130 (DIN 931), (10.9)	2	M12 (DIN 985), (.10)
	1	M14x130 (DIN931),(10.9)	1	M14 (DIN985), (.10)

12512KIT7070



12512



# 4.8 DISC SUPPORT SUPPORT DE DISQUE

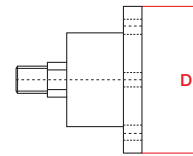
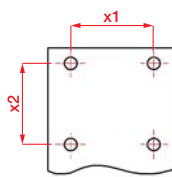
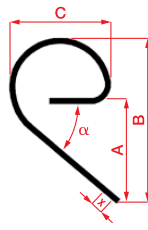
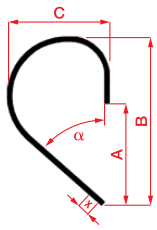

## 2512 BRG A CA1

Ref. Réf.	Chasis Châssis	Grs.		A	B	C	x1	x2	$\alpha$	M	
2512 BRG A CA1	60X60 / 70X70	9.000	90X14	273	429	264	60	30	40°	M12 (4)	100

Fixes to frame with 2 bolts of 14 mm metrics and 60 mm of distance between the two holes. / Fixation au châssis avec 2 boulons de métrique 14 et 60 mm the distance entre les deux trous.

2512 BRG A CA1



## 2512 BRG B

Ref. Réf.	Chasis Châssis	Grs.		A	B	C	x1	x2	$\alpha$	M	
2512 BRG B	70x70	7.600	90X14	265	440	267	60	30	48,6°	M12 (4)	100

Fixes to frame with 2 bolts of 16 metrics and 50 mm of distance between the two holes. / Fixation au châssis avec 2 boulons de métrique 16 et 50 mm the distance entre les deux trous.

2512 BRG B



## 2512 SB

Ref. Réf.	Angle	Grs.	
2512 SB	19°	3.500	100

For BAA or HUB type bushes. Also can be tailor-made according to the requirement of each client. / Pour moyeu type BAA ou HUB. Aussi conçue sure mesure pour chaque client.

Ambidextrous / Ambidextre

Fixes to BRG tines with 4 bolts of 12 metrics, not included / Fixation au dent avec 4 boulons de métrique 14, non inclus  
We recommend to mount with flat center blades, models 1960, 1961 and 1965. / On recommande le montage avec disques à fond plat, models 1960, 1961 et 1965.

2512-SB



2512SB



## 2512 SB R

Ref. Réf.	Angle	Grs.	
2512 SB R	90°	3.500	100

Common to all BRG tines / Commom à tous les bras BRG  
Ambidextrous / Ambidextre

For BAA or HUB type bushes. Also can be tailor-made according to the requirement of each client. / Pour moyeu type BAA ou HUB. Aussi conçue sur mesure pour chaque client.

Fixes to BRG tines with 4 bolts of 12 metrics, not included / Fixation au dent avec 4 boulons de métrique 12, non inclus



2512SB R



2512SBR



## DOUBLE COIL TINES FOR DISC HARROW / DENTS À DOUBLE SPIRE POUR COVER CROP

Ref. Réf.	Grs.			<b>F</b>
2486-E D	18.500	35x35	50	50
2486-E I	18.500	35x35	50	50
2486-SH D	18.050	35x35	50	50
2486-SH I	18.050	35x35	50	50

Tailor-made tine design. We do not have the assemble with the bushing. / Dent conçue sur mesure. Nou n'avons pas le montage pour le moyeu.

2486-E



2486-E





2485/2486-SH



2485/2486-SH



## Hub / Moyeu

Ref. Réf.	D	M	T	Grs.		
BUJEBRG30984	117	M12x1,25 (4)	M22x1,25	2000	2	500
BUJEBRG30986	117	M12x1,25 (6)	M22x1,5	2000	2	500
BUJEBRG351125	140	M12x1,5 (5)	M24x2	2550	2	500

BUJEBRG30984

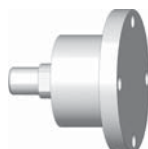

BUJEBRG30986

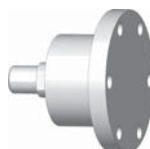

BUJEBRG351125

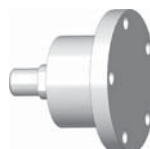

I Left / Gauche

D Right / Droite

F Articles manufactured upon order / Fabrication de l'article sur commande